

SERVICELINE

Catering & Refrigeration Equipment Sales  Est. 1989



**FALCON E3121 4HP ELECTRIC
DOMINATOR PLUS FOUR HOTPLATE BOILING TOP**

FALCON E3121 4HP ELECTRIC DOMINATOR PLUS FOUR HOTPLATE BOILING TOP

SPECIFICATION DETAILS	E3121 4HP
Electrical rating (kW)	10.4
Electrical supply voltage	400V 3N~
Minimum electrical supply 400V 3N~ (A)	20
Electrical current split (A)	L1: 16 L2: 14 L3: 14
Hotplate rating (kW)	3.2 x 3
Weight (kg)	71
Weight on stand (kg)	101
Packed weight (kg)	83
Packed dimensions (w x d x h - mm)	1000 x 1000 x 600

KEY FEATURES

- Two full depth rectangular hotplates and two fast - heating circular hotplates - Allows multiple cooking positions
- Independently controlled hotplates- Provides flexibility to chef
- Full width, removable drip tray - Easy to remove and keep clean
- Variable, accurate temperature control - Ideal for a wide range of menu items
- Laser-etched control icons - Permanent, indelible markings

ACCESSORIES

- Fixed stand
- Factory fitted, adjustable castors
- Fixed installation kit

Similar Models

- E3121 3HP boiling top
- E3122 2HP boiling top
- E9084 4HP boiling top

INSTALLATION NOTE

Adequate ventilation must be provided to supply sufficient fresh air and to allow easy removal of any such products that may present a risk to health. Please consult current legislation for details that relate to specific locations.

Install unit on a level, fireproof surface in a well-lit position. If floor is made of a combustible material, local fire requirements must be checked to ensure compliance. A clearance of 150mm should be observed between appliance and any combustible wall

DIMENSIONS MEASUREMENTS IN MM

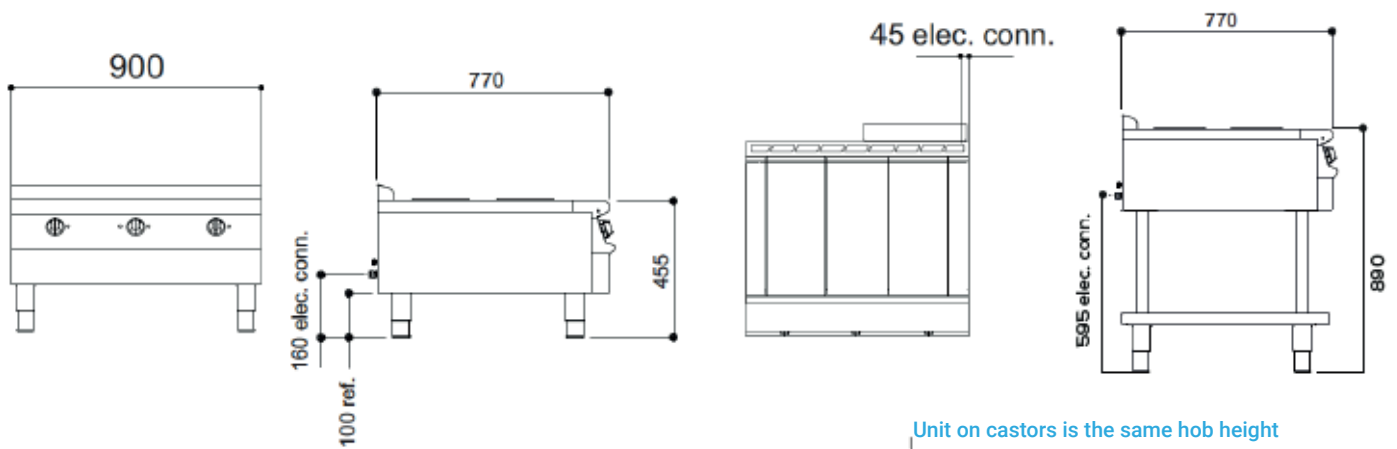

SERVICELINE

Catering & Refrigeration Equipment Sales  Est. 1989



01438 363 040

ServiceLine 1 Icen Ct, Icknield Way, Letchworth Garden City SG6 1TN