

SERVICELINE

Catering & Refrigeration Equipment Sales  Est. 1989



**FALCON E312 ELECTRIC
DOMINATOR PLUS TWO HOTPLATE BOILING TOP**

FALCON E3122 ELECTRIC DOMINATOR PLUS TWO HOTPLATE BOILING TOP

SPECIFICATION DETAILS	E3122
Electrical rating (kW)	4
Electrical supply voltage	230V
Minimum electrical supply 400V 3N~ (A)	2016
Electrical current split (A)	L1: 16
Hotplate rating (kW)	2 X 2
Weight (kg)	25
Weight on stand (kg)	43
Packed weight (kg)	33
Packed dimensions (w x d x h - mm)	450 x 1000 x 600

KEY FEATURES

- Features two fast-heating circular hotplates - Rapid heat up times
- Plunged hob contains spillages - Easy and quick to clean
- Variable, accurate temperature control - Ideal for a wide range of menu items
- Laser-etched control icons- Permanent, indelible markings

ACCESSORIES

- Fixed stand
- Factory fitted, adjustable castors
- Fixed installation kit

Similar Models

- E3121 3HP boiling top
- E3121 3HP boiling top
- E9042 2HP boiling top

INSTALLATION NOTE

Adequate ventilation must be provided to supply sufficient fresh air and to allow easy removal of any such products that may present a risk to health. Please consult current legislation for details that relate to specific locations.

Install unit on a level, fireproof surface in a well-lit position. If floor is made of a combustible material, local fire requirements must be checked to ensure compliance. A clearance of 150mm should be observed between appliance and any combustible wall.

DIMENSIONS MEASUREMENTS IN MM

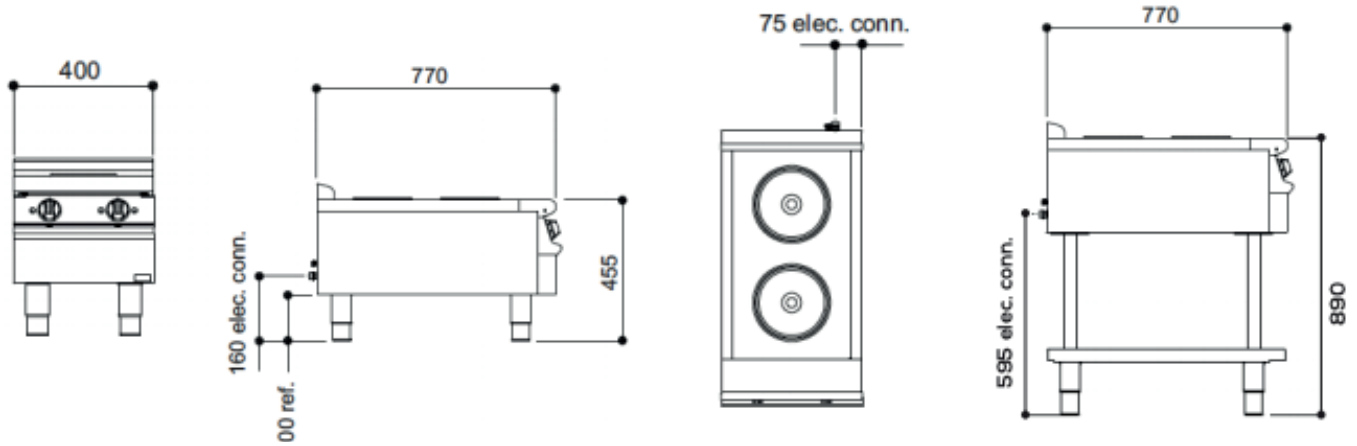

SERVICELINE

Catering & Refrigeration Equipment Sales  Est. 1989



01438 363 040

ServiceLine 1 Icen Ct, Icknield Way, Letchworth Garden City SG6 1TN