

SERVICELINE

Catering & Refrigeration Equipment Sales  Est. 1989



**FALCON E3625 ELECTRIC
DOMINATOR PLUS CHARGRILL**

FALCON E3625 ELECTRIC DOMINATOR PLUS CHARGRILL

SPECIFICATION DETAILS	E3625
Electrical rating (kW)	8.4
Electrical supply voltage	400V 3N~
Cooking area (w x d - mm)	450 x 590
Required electrical supply (A)	32
Electrical current split (A)	L1: 11 / L2: 15 / L3: 11
Weight (kg)	47
Packed weight (kg)	56.5

KEY FEATURES

- Element heats up very quickly
- Cook directly on element
- Removable grease container needs no water
- Switch on as and when required, saving energy
- Delivers branding marks expected of chargrilling Provides even cooking across the entire cooking area
- No having to separate grease and water for disposal

ACCESSORIES

- Stand with storage shelf on legs
- Stand with factory fitted, adjustable castors
- Grease collection system for stand
- Fixed installation kit for stand
- Suiting kit

SIMILAR MODELS

- E9460 electric chargrill (F900)
- E9490 electric chargrill (F900)
- E3925 electric chargrill (Dominator Plus)

INSTALLATION NOTE

Adequate ventilation must be provided to supply sufficient fresh air for combustion and to allow easy removal of any such products that may present a risk to health. Please consult current legislation for details that relate to specific locations.

Install unit on a level, fireproof surface in a well-lit, draught free position. If floor is made of a combustible material, local fire requirements must be checked to ensure compliance.

A clearance of 150mm should be observed between appliance and any combustible wall.

SPECIFICATIONS AND DIMENSIONS

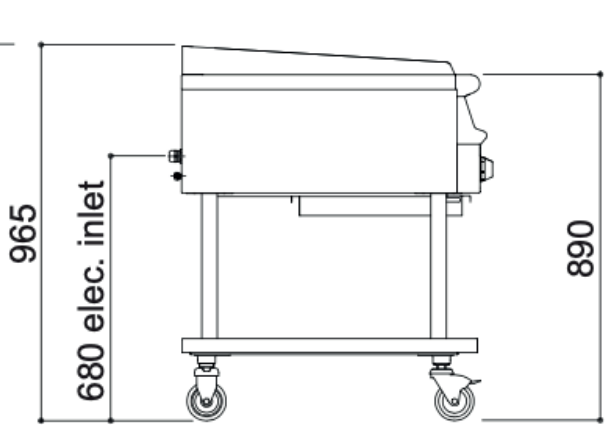
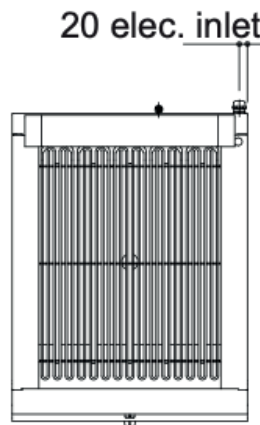
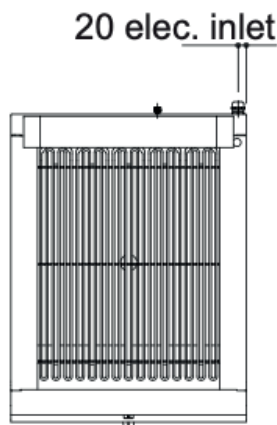
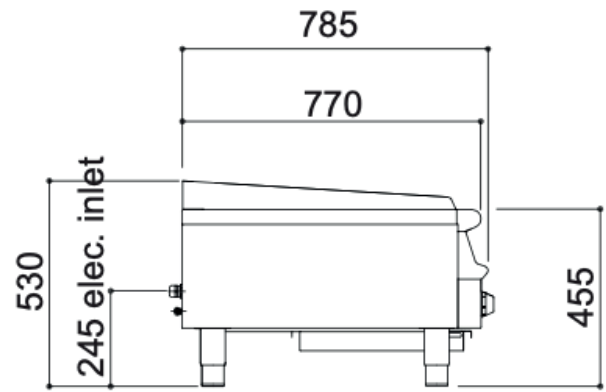
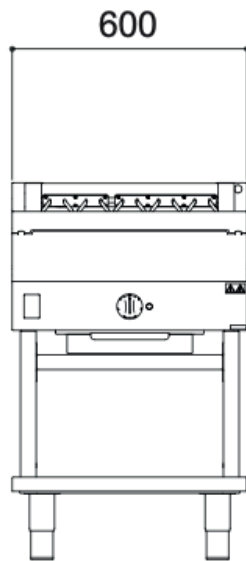
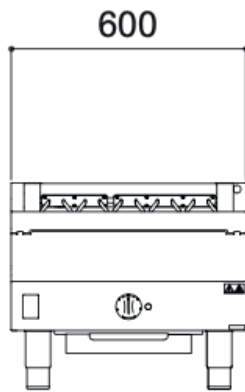

SERVICELINE

Catering & Refrigeration Equipment Sales  Est. 1989



01438 363 040

ServiceLine 1 Icen Ct, Icknield Way, Letchworth Garden City SG6 1TN