

SERVICELINE

Catering & Refrigeration Equipment Sales  Est. 1989



**FALCON G3925 GAS
DOMINATOR PLUS RADIANT CHARGRILL**

FALCON G3925 GAS DOMINATOR PLUS RADIANT CHARGRILL

SPECIFICATION DETAILS	G3925
Total rating (kW - Nett)	26.0
Total rating (btu/hr - gross)	98,737
Inlet size	3/4" BSP
Flow rate - Natural gas (m ³ /hr)	2.58
Flow rate - Propane gas (kg/hr)	2.04
Inlet pressure (mbar)	20 / 37
Operating pressure (mbar)	15 / 37
Cooking area (w x d - mm)	860 x 630
Number of burners	3
Number of branders	9
Weight (kg)	205
Weight on stand (kg)	235
Packed weight (kg)	219
Packed dimensions (w x d x h - mm)	1000 x 1000 x 650

KEY FEATURES

- 3 x 8.6kW cast iron burners - Quick heat up, reduced waiting time
- Reversible, angled, heavy duty cast iron brander bars - Delivers even heat across entire cooking surface
- Full width cooking area - Maximum output
- Independently controlled burners - Vary heat across unit if required or even turn one side off during quieter periods
- Removable stainless steel surround - Ensures adjacent equipment remains spatter free
- Grease collection tray at front of unit - Catches and contains grease and fat
- Full width debris collection tray below unit - Catches all grease and debris
- Large capacity grease collection container - Easy to remove and empty during service
- Cast iron burners with variable control / turndown - Ensures chargrill is at the desired temperature
- Laser-etched control icons - Permanent, indelible markings

ACCESSORIES

- Griddle plate
- V bars
- Fixed stand
- Factory fitted, adjustable castors
- Fixed installation kit

SIMILAR MODELS

- G3625 radiant chargrill
- G9460 radiant chargrill
- G9490 radiant chargrill
- E3925 electric chargrill

INSTALLATION NOTES

Adequate ventilation must be provided to supply sufficient fresh air and to allow easy removal of any such products that may present a risk to health. Please consult current legislation for details that relate to specific locations.

Install unit on a level, fireproof surface in a well-lit position.

A clearance of 150mm should be observed between appliance and any combustible wall. Please consult the appliance installation manual for further details.

DIMENSIONS MEASUREMENTS IN MM

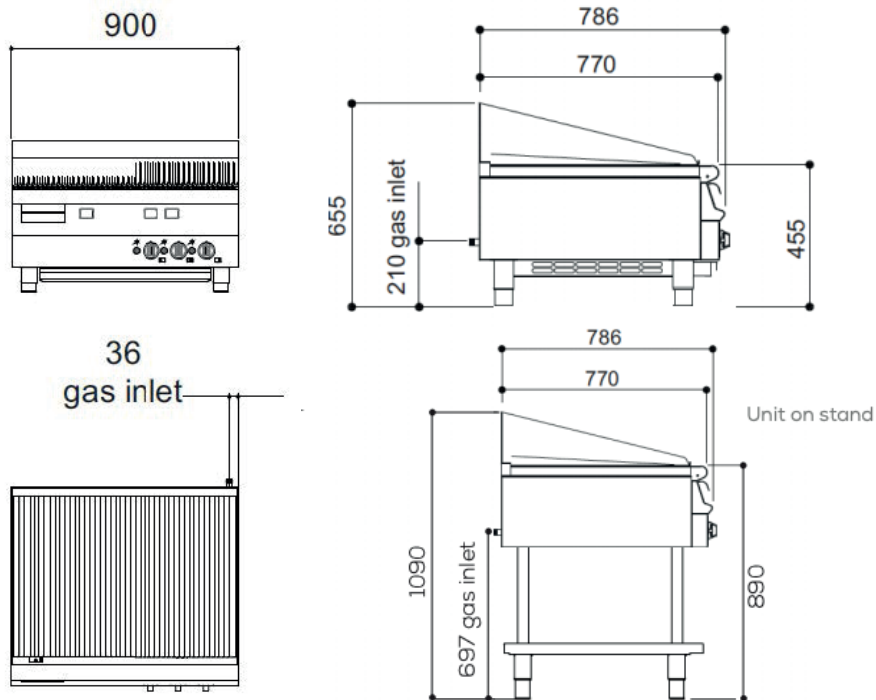

SERVICELINE

Catering & Refrigeration Equipment Sales  Est. 1989



01438 363 040

ServiceLine 1 Icen Ct, Icknield Way, Letchworth Garden City SG6 1TN