

SERVICELINE

Catering & Refrigeration Equipment Sales  Est. 1989



**FALCON E9084 ELECTRIC
F900 FOUR HOTPLATE BOILING TOP**

FALCON E9084 ELECTRIC F900 FOUR HOTPLATE BOILING TOP

SPECIFICATION DETAILS	E9084
Electrical rating (kW)	16
Electrical supply voltage	400V 3N~ 50/60Hz
Required electrical supply (A)	63
Electrical current split (A)	L1: 34.6, L2: 17.3, L3: 17.3
Element rating - hob (kW)	4 x 4
Size of hotplate (w x d - mm)	300 x 300
Weight (kg)	70
Weight on stand (kg)	86
Packed weight (kg)	92
Packed dimensions (w x d x h - mm)	1000 x 1000 x 780

KEY FEATURES

- 4 x high performance, 4kW cast iron hotplates - Quick heat up, reduced waiting time
- Each hotplate has 6 heat positions - Precise temperature control
- Pressed hob wells - Contains spillages, making it easier to clean
- IPX5 rated - Easy and problem-free cleaning
- Stainless steel panels with Scotch Brite finish - Looks great, ideal for front-of-house kitchens
- Dynamic Link System compatible - Integrated linking system allows quick and easy installation to create a seamless, continuous cookline

ACCESSORIES

- Fixed stand (ST80)
- Trivet
- Front hob rail
- Kick strip (for stand)
- Rear blanking plate (for stand)
- Side hob extension
- Factory fitted, adjustable castors

Similar Models

- E9184 four hotplate oven range
- E3101 3 hotplate boiling top
- E3101 4 hotplate boiling top
- E3101P 6 hotplate boiling top
- G9084 four burner gas boiling top

SHORT FORM SPECIFICATION

Unit to be Falcon F900 Series four hotplate electric boiling top having 4 x 4kW electric cast iron hotplates. Unit to be supplied upon adjustable feet or upon optional base unit.

The hob will be constructed from 2mm 304 grade stainless steel. Hobs will be laser cut with right-angled edges to allow joining of units with no gaps between hobs. Exterior panels are Scotch Brite finish stainless steel. Control knobs to be marked showing temperature positions and to have a bezel behind each knob to prevent water ingress.

INSTALLATION NOTE

Please consult local legislation with regard to installation of cooking equipment.

DIMENSIONS MEASUREMENTS IN MM

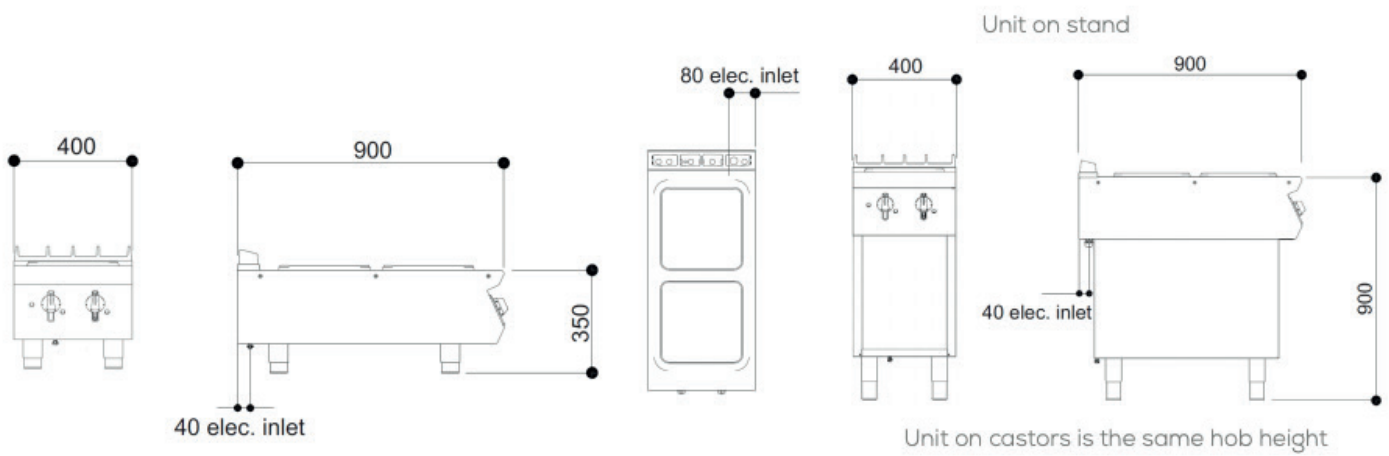

SERVICELINE

Catering & Refrigeration Equipment Sales  Est. 1989



01438 363 040

ServiceLine 1 Icen Ct, Icknield Way, Letchworth Garden City SG6 1TN