

SERVICELINE

Catering & Refrigeration Equipment Sales  Est. 1989



**FALCON G9081 GAS
F900 SINGLE BULLSEYE BOILING TABLE**

FALCON G9081 GAS F900 SINGLE BULLSEYE BOILING TABLE

SPECIFICATION DETAILS	Natural Gas	Propane Gas	Butane Gas
Total rating (kW - Nett)	10.3	10.3	10.3
Total rating (btu/hr - gross)	38,669	38,669	38,669
Inlet size	3/4" BSP	3/4" BSP	3/4" BSP
Flow rate - natural (m ³ /hr)	1.01 m ³ /hr	1.01 m ³ /hr	1.01 m ³ /hr
Inlet pressure (mbar)	20	37	29
Operating pressure (mbar)	15	37	29
Hob burner rating * (kW)	10.3	10.3	10.3
Hob burner rating * (btu/hr)	38,669	38,669	38,669
Weight (kg)	92	92	92
Packed weight (kg)	108	108	108
Packed dimensions (w x d x h - mm)	1000 x 1000 x 780	1000 x 1000 x 780	1000 x 1000 x 780

KEY FEATURES

- High performance 10.3kW cast iron burner - Quick heat up, reduced waiting time
- 50mm thick cast iron plates - Conducts and retains heat efficiently
- Removable central sections - Heat pans on direct heat when required
- Central burner delivers graduated heat up to 450°C - Ensures plate has different temperatures for maximum versatility
- Stainless steel panels with Scotch Brite finish - Looks great, ideal for front-of-house kitchens
- Dynamic Link System compatible - Integrated linking system allows quick and easy installation to create a seamless, continuous cookline

ACCESSORIES

- Fixed stand (ST80)
- Front hob rail
- Side hob extension
- Kick strip (for stand)
- Rear blanking plate (for stand)
- Factory fitted, adjustable castors for stand

Similar Models

- G9181 solid top oven range
- G9084 four burner boiling top
- G9184 four burner oven range
- E9084 four hotplate boiling top

Short Form specification

Unit to be Falcon F900 Series gas solid top unit having a 10.3kW central gas burner and to be supplied upon adjustable feet and to be installed upon open base cabinet or stand. Burner with flame failure device as standard to guard against being extinguished accidentally.

The cooking surface will be made from 50mm thick cast iron and will be in sections to allow removal for ease of cleaning.

The hob will be constructed from 2mm 304 grade stainless steel. Hobs will be laser cut with right-angled edges to allow joining of units with no gaps between hobs. Exterior panels are Scotch Brite finish stainless steel. Control knobs to be marked showing gas positions and to have a bezel behind each knob to prevent water ingress. Unit will be for use with natural, propane or butane gas and be supplied with conversion kit.

INSTALLATION NOTE

Please consult local legislation with regard to installation of cooking equipment.

DIMENSIONS MEASUREMENTS IN MM

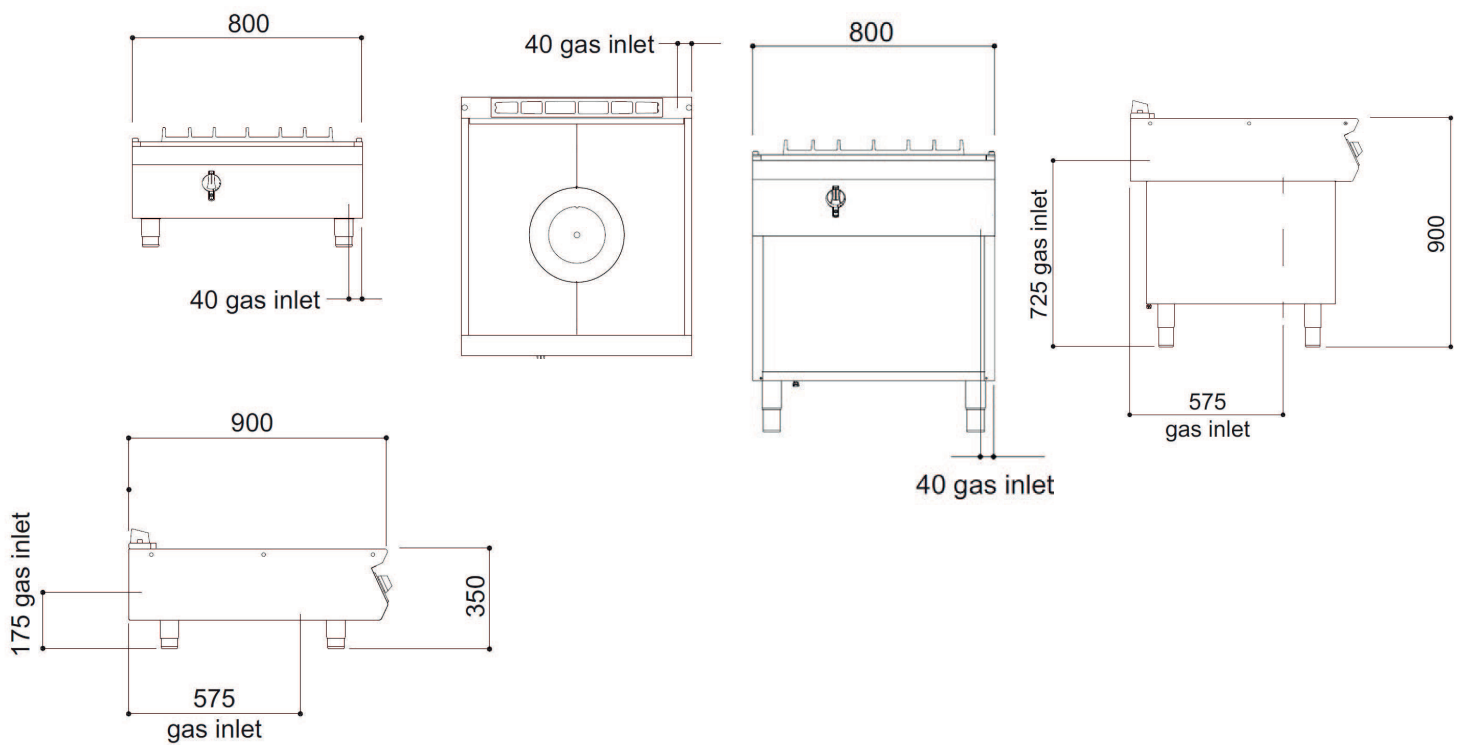

SERVICELINE

Catering & Refrigeration Equipment Sales  Est. 1989



01438 363 040

ServiceLine 1 Icen Ct, Icknield Way, Letchworth Garden City SG6 1TN