

# SERVICELINE

Catering & Refrigeration Equipment Sales  Est. 1989



**FALCON E3512 ELECTRIC  
DOMINATOR PLUS GRILL**

# FALCON E3512 ELECTRIC DOMINATOR PLUS GRILL

SPECIFICATION DETAILS	E3512
Electrical rating (kW)	5.2
Electrical supply voltage	230V N~
Amps per phase (A)	L1: 22.5
Gastronorm compatibility	1/1
Weight (kg)	57
Packed weight (kg)	67
Packed dimensions (w x d x h - mm)	800 x 600 x 700

## KEY FEATURES

- Single element controlled by energy regulator - Easy to adjust cooking temperature
- Double-cased with internal insulation - Provides optimal heat retention
- Supplied with reversible brander - Increases cooking versatility
- Five position shelf runners - Provides flexible cooking options
- Gastronorm compatible - Takes 1/1 GN tray so ideal for bulk cooking
- Oil collection tray mounted on grid shelf - Catches any liquid grese during grilling
- Removable drip tray - Catches grease and debris during grilling
- All stainless steel exterior, cast iron chamber linings - Easy to clean, long lasting and robust

## ACCESSORIES

- Brander
- Brander carrier
- Floor stand
- Wall bracket
- Bench Legs

## ACCESSORIES

- E3532 electric grill
- G3512 gas grill
- G3532 gas grill

## INSTALLATION NOTE

Adequate ventilation must be provided to supply sufficient fresh air and to allow easy removal of any such products that may present a risk to health. Please consult current legislation for details that relate to specific locations.

A clearance of 150mm should be observed between appliance and any combustible wall.

## SPECIFICATIONS AND DIMENSIONS

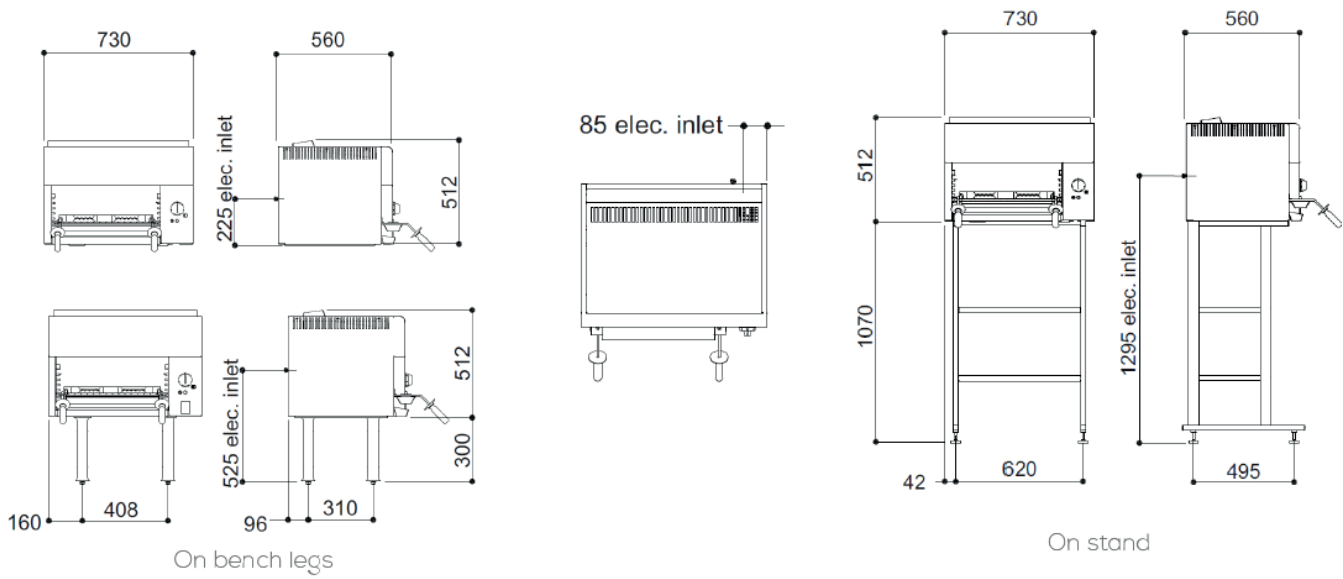

# SERVICELINE

Catering & Refrigeration Equipment Sales  Est. 1989



01438 363 040

ServiceLine 1 Icen Ct, Icknield Way, Letchworth Garden City SG6 1TN