

# SERVICELINE

Catering & Refrigeration Equipment Sales  Est. 1989



**FALCON E9781-100 ELECTRIC  
F900 BOILING PAN**

## FALCON E9781-100 ELECTRIC F900 SERIES BOILING PAN

SPECIFICATION DETAILS	E9781-100
Electrical rating (kW)	16
Electrical supply voltage	400V 3N~ 50/60Hz
Required electrical supply (A)	32
Electrical current split (A)	L1: 23.1, L2: 23.1, L3: 23.1
Element rating (kW)	16
Water capacity (litres)	100
Water connection	3/4" BSP
Water pressure (kPa)	50-300
Draw off (diameter)	2"
Weight (kg)	140
Packed weight (kg)	165
Packed dimensions (mm)	870 (w) x 1070 (d) x 1270 (h)

### KEY FEATURES

- 100 litre stainless steel pan - Ideal for bulk cooking
- Integrated water faucet - Quick and easy to add water as required
- Counter-balanced lid - Leave lid as open as required during cooking
- Indirect heating system - Dual pans protect contents from excessive heat
- Stainless steel panels with Scotch Brite finish - Looks great, ideal for front-of-house kitchens
- Dynamic Link System compatible - Integrated linking system allows quick and easy installation to create a seamless, continuous cookline

### ACCESSORIES

- Front hob rail
- Kick strip
- Rear blanking plate
- Side hob extension
- Factory fitted, adjustable castors

### SIMILAR MODELS

- E9781-150 gas boiling pan (150 litres)
- G9781-100 gas boiling pan (100 litres)
- G9781-150 gas boiling pan (150 litres)

### SHORT FORM SPECIFICATION

Unit to be Falcon F900 Series electric boiling pan having a 100 litre capacity pan to be supplied upon adjustable feet.

The hob will be constructed from 2mm 304 grade stainless steel. Hobs will be laser cut with right-angled edges to allow joining of units with no gaps between hobs. Exterior panels are Scotch Brite finish stainless steel. Control knobs to be marked showing temperature positions and to have a bezel behind each knob to prevent water ingress.

### INSTALLATION NOTE

Please consult local legislation with regard to installation of cooking equipment.

## DIMENSIONS MEASUREMENTS IN MM

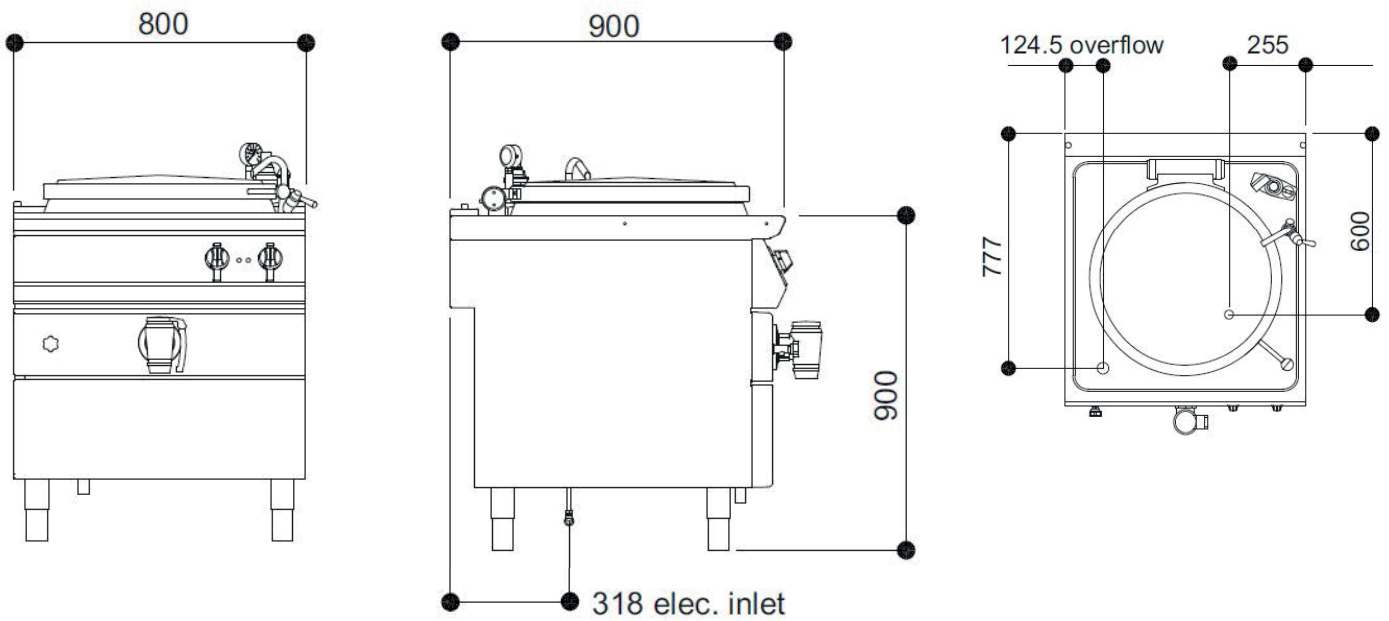



# SERVICELINE

Catering & Refrigeration Equipment Sales  Est. 1989



01438 363 040

ServiceLine 1 Icen Ct, Icknield Way, Letchworth Garden City SG6 1TN