

# SERVICELINE

Catering & Refrigeration Equipment Sales  Est. 1989



**FALCON G2994 GAS  
CHIEFTAIN BRATT PAN**

## FALCON G2994 GAS CHIEFTAIN BRATT PAN

SPECIFICATION DETAILS	G2994
Total rating (natural and propane - kW - Nett)	15.9
Total rating (natural and propane - btu/hr - gross)	59,700
Inlet size (natural and propane)	1/2" BSP
Flow rate - natural (m <sup>3</sup> /hr)	1.68
Flow rate - propane (kg/hr)	1.24
Inlet pressure (natural and propane - mbar)	15 / 37
Operating pressure (natural and propane - mbar)	15 / 35
Electrical supply voltage	230V~
Amps per phase (A)	3
Pan dimensions (w x d x h - mm)	800 x 530 x 140
Oil capacity (litres)	21
Water capacity (litres)	60
Weight (kg)	165
Packed weight (kg)	178
Packed dimensions (w x d x h - mm)	1000 x 1000 x 1100

### KEY FEATURES

- Heavy duty cast iron pan - Delivers consistently even heating across the pan
- Versatile cooking performance - Able to carry out seven different cooking methods, including frying
- Manual tilt via front located handle - Safe, smooth pan tilting
- Incremental opening lid - See what's cooking without unnecessary heat loss
- Precise temperature control from 100 - 300°C - Responsive and accurate controls
- Automatic power cut-off when pan is tilted - Additional safety feature for added peace of mind

### ACCESSORIES

- Cradle
- Factory fitted, adjustable castors

### SIMILAR MODELS

- G2962 37 litre bratt pan
- G3800DX duplex bratt pan
- G9881 duplex bratt pan
- E2962 37 litre electric bratt pan
- E2994 60 litre electric bratt pan

### INSTALLATION NOTES

Adequate ventilation, whether natural or mechanical, must be provided to supply sufficient fresh air for combustion and to allow easy removal of such products that may present risk to health. Recommendations for ventilation of appliances are given in BS5440:2 and HVCA specification DW/172. For multiple installations, requirements for individual appliances should be added together. Installation of any such system must be completed in accordance with local and/or national regulations that apply at time of commissioning.

The appliance must be installed on a firm, level floor in a well lit position. Unit supplied upon adjustable feet for levelling if required.

## DIMENSIONS MEASUREMENTS IN MM

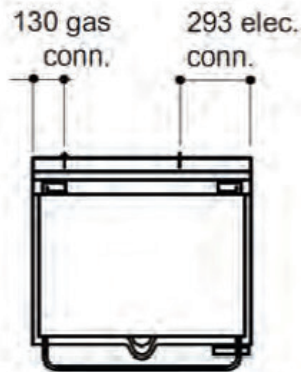

Measurements *in mm*

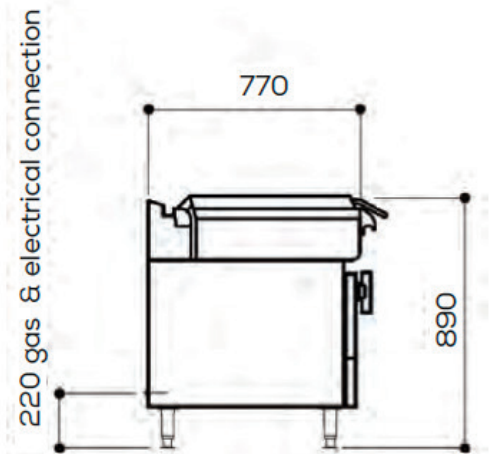

Unit on castors is same height

# SERVICELINE

Catering & Refrigeration Equipment Sales  Est. 1989



01438 363 040

ServiceLine 1 Icen Ct, Icknield Way, Letchworth Garden City SG6 1TN