

SERVICELINE

Catering & Refrigeration Equipment Sales  Est. 1989



**FALCON G3101HD GAS
DOMINATOR PLUS OPEN TOP RANGE**

FALCON G3101HD GAS DOMINATOR PLUS OPEN TOP RANGE

SPECIFICATION DETAILS	G3101HD
Total rating (natural - kW - Nett)	48.5
Total rating (propane - kW - Nett)	47.3
Total rating (natural - btu/hr - gross)	182,000
Total rating (propane - btu/hr - gross)	178,000
Inlet size (natural and propane)	3/4" BSP
Flow rate - natural (m ³ /hr)propane - mbar)	5.10
Flow rate - propane (kg/hr)	3.70
Inlet pressure (natural and propane - mbar)	20 / 37
Operating pressure (natural and propane - mbar)	15 / 37
Hob burner rating * (natural - kW)	6.9 x 6
Hob burner rating * (propane - kW)	6.7 x 6
Hob burner rating * (natural - btu/hr)	25,900 x 6
Hob burner rating * (propane - btu/hr)	25,200 x 6
Oven burner rating * (natural and propane - kW)	7.1
Oven burner rating * (natural and propane - btu/hr)	26,600
Oven dimensions (w x d x h - mm)	700 x 535 x 430
Oven shelf (w x d - mm)	700 x 535
Gastronorm compatibility	2/1
Weight (kg)	109
Packed weight (kg)	122
Packed dimensions (w x d x h - mm)	1000 x 1000 x 1300

KEY FEATURES

- Energy efficient, high performance, twin flame 6.9kW burners - Quick heat up, reduced waiting time
- Three x twin heavy duty cast iron pan supports - Long-lasting and robust
- Vitreous enamelled oven chamber - Easy to clean and to keep clean
- Wide oven temperature range of 120 - 270°C - Ideal to prepare a wide variety of food
- Piezo ignition to oven - Simple, trouble-free operation
- Drop down door with full width handle - Quick and easy access to the oven
- Oven has 5 shelf positions and allows 2 shelf cooking - Versatile, ideal for a wide range of menu items
- Supplied with back castors and front legs - Easier to move into place and adjust height
- Laser-etched control icons - Permanent, indelible markings

ACCESSORIES

- Fully integrated extended flue
- Splashplate and plate shelf (not for use with extended flue)
- Oven shelf
- Lift-off fryplate
- Factory fitted, adjustable castors
- Fixed installation kit

SIMILAR MODELS

- G3101 Six burner range
- G3101D Six burner range with drop down door
- G3101 OTC Six burner range - electric fan assisted oven
- G3106 Six burner range - gas fan assisted oven
- G3161 Four burner range - general purpose oven

INSTALLATION NOTE

Adequate ventilation must be provided to supply sufficient fresh air for combustion and to allow easy removal of any such products that may present a risk to health. Please consult current legislation for details that relate to specific locations.

Install unit on a level, fireproof surface in a well-lit, draught free position. If floor is made of a combustibile material, local fire requirements must be checked to ensure compliance.

A clearance of 150mm should be observed between appliance and any combustibile wall.

SPECIFICATIONS AND DIMENSIONS

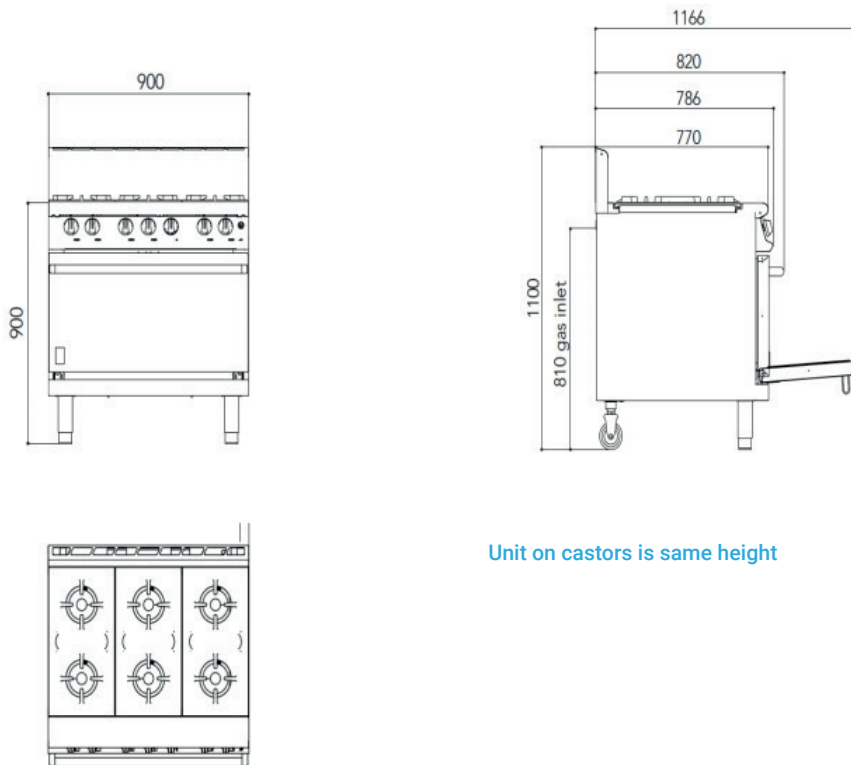

Unit on castors is same height

SERVICELINE

Catering & Refrigeration Equipment Sales  Est. 1989



01438 363 040

ServiceLine 1 Icen Ct, Icknield Way, Letchworth Garden City SG6 1TN