

SERVICELINE

Catering & Refrigeration Equipment Sales  Est. 1989



**FALCON G3107 GAS
DOMINATOR PLUS SOLID TOP RANGE**

FALCON G3107 GAS DOMINATOR PLUS SOLID TOP RANGE

SPECIFICATION DETAILS	G3107
Total rating (natural and propane - kW - Nett)	17.3
Total rating (natural and propane - btu/hr - gross)	64,900
Inlet size (natural and propane)	3/4" BSP
Flow rate - natural (m ³ /hr)	1.83
Flow rate - propane (kg/hr)	1.34
Inlet pressure (natural and propane - mbar)	20 / 37
Oven operating pressure (natural and propane - mbar)	15 / 37
Hob burner rating * (natural and propane - kW)	10.2
Hob burner rating * (natural and propane - btu/hr)	38,300
Oven burner rating * (natural and propane - kW)	7.1
Oven burner rating * (natural and propane - btu/hr)	26,600
Oven dimensions (w x d x h - mm)	700 x 535 x 430
Oven shelf (w x d - mm)	700 x 535
Gastronorm compatibility	2/1
Weight (kg)	137
Packed weight (kg)	150
Packed dimensions (w x d x h - mm)	1000 x 1000 x 1100

KEY FEATURES

- Solid top model with removable bullseye - Can deliver heat up to 400°C when required
- 18mm thick cast iron solid top - Robust and hard-wearing, enough to perform in tough environments
- Graduated heat across the cooking surface - Move pans to suit what you're cooking
- Vitreous enamelled oven chamber - Easy to clean and to keep clean
- Wide oven temperature range of 120 - 270°C - Ideal to prepare a wide variety of food
- Piezo ignition to oven - Simple, trouble-free operation
- Twin oven doors with individual catches - Retains heat within the oven chamber
- Oven has 5 shelf positions and allows 2 shelf cooking - Versatile, ideal for a wide range of menu items
- Low profile door handles - Reduces intrusion into work space
- Laser-etched control icons - Permanent, indelible markings

ACCESSORIES

- Fully integrated extended flue
- Splashplate and plate shelf (not for use with extended flue)
- Oven shelf
- Lift-off fryplate
- Factory fitted, adjustable castors
- Fixed installation kit

SIMILAR MODELS

- G9181 solid top range
- G3127 solid top boiling top
- G3101HD Six burner heavy duty range
- G3101D Six burner range with drop down door
- G3101 OTC Six burner range - electric fan assisted oven
- G3106 Six burner range - gas fan assisted oven
- G3161 Four burner range - general purpose oven

INSTALLATION NOTE

Adequate ventilation must be provided to supply sufficient fresh air for combustion and to allow easy removal of any such products that may present a risk to health. Please consult current legislation for details that relate to specific locations.

Install unit on a level, fireproof surface in a well-lit, draught free position. If floor is made of a combustible material, local fire requirements must be checked to ensure compliance.

A clearance of 150mm should be observed between appliance and any combustible wall.

DIMENSIONS MEASUREMENTS IN MM

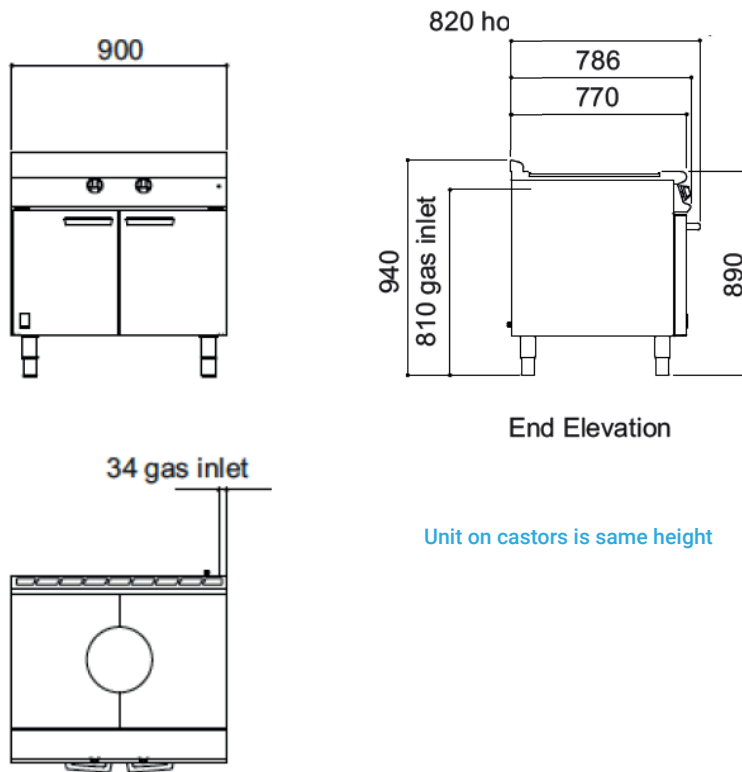

End Elevation

Unit on castors is same height

SERVICELINE

Catering & Refrigeration Equipment Sales  Est. 1989



01438 363 040

ServiceLine 1 Icen Ct, Icknield Way, Letchworth Garden City SG6 1TN