

# SERVICELINE

Catering & Refrigeration Equipment Sales  Est. 1989



**FALCON G3532 GAS  
DOMINATOR PLUS GRILL**

# FALCON G3532 GAS DOMINATOR PLUS GRILL

SPECIFICATION DETAILS	G3532
Total rating (natural and propane - kW - Nett)	6.65
Total rating (natural and propane - btu/hr - gross)	24,960
Inlet size (natural and propane)	1/2" BSP
Flow rate - natural (m <sup>3</sup> /hr)	0.70
Flow rate - propane (kg/hr)	0.52
Inlet pressure (natural and propane - mbar)	20 / 37
Operating pressure (natural and propane - mbar)	15 / 37
Brander (w x d - mm)	540 x 275
Weight (kg)	33
Packed weight (kg)	40
Packed dimensions (w x d x h - mm)	800 x 400 x 550

## KEY FEATURES

- High performance burner systems - Ideal for flashing and finishing
- Variable heat settings - Save energy when full heat is not required
- Supplied with reversible brander - Increases cooking versatility
- Five position shelf runners - Provides flexible cooking options
- Gastronorm compatible - Takes 1/1 GN tray so ideal for bulk cooking
- Oil collection tray mounted on grid shelf - Catches any liquid grese during grilling
- Removable drip tray - Catches grease and debris during grilling
- All stainless steel exterior, cast iron chamber linings - Easy to clean, long lasting and robust

## ACCESSORIES

- Brander
- Brander carrier
- Floor stand
- Wall bracket
- Bench Legs

## SIMILAR MODELS

- G3512 gas grill
- E3532 electric grill
- E3512 electric grill

## INSTALLATION NOTE

Adequate ventilation must be provided to supply sufficient fresh air for combustion and to allow easy removal of any such products that may present a risk to health. Please consult current legislation for details that relate to specific locations.

Install unit on a level, fireproof surface in a well-lit, draught free position. If floor is made of a combustible material, local fire requirements must be checked to ensure compliance. A clearance of 150mm should be observed between appliance and any combustible wall.

## SPECIFICATIONS AND DIMENSIONS

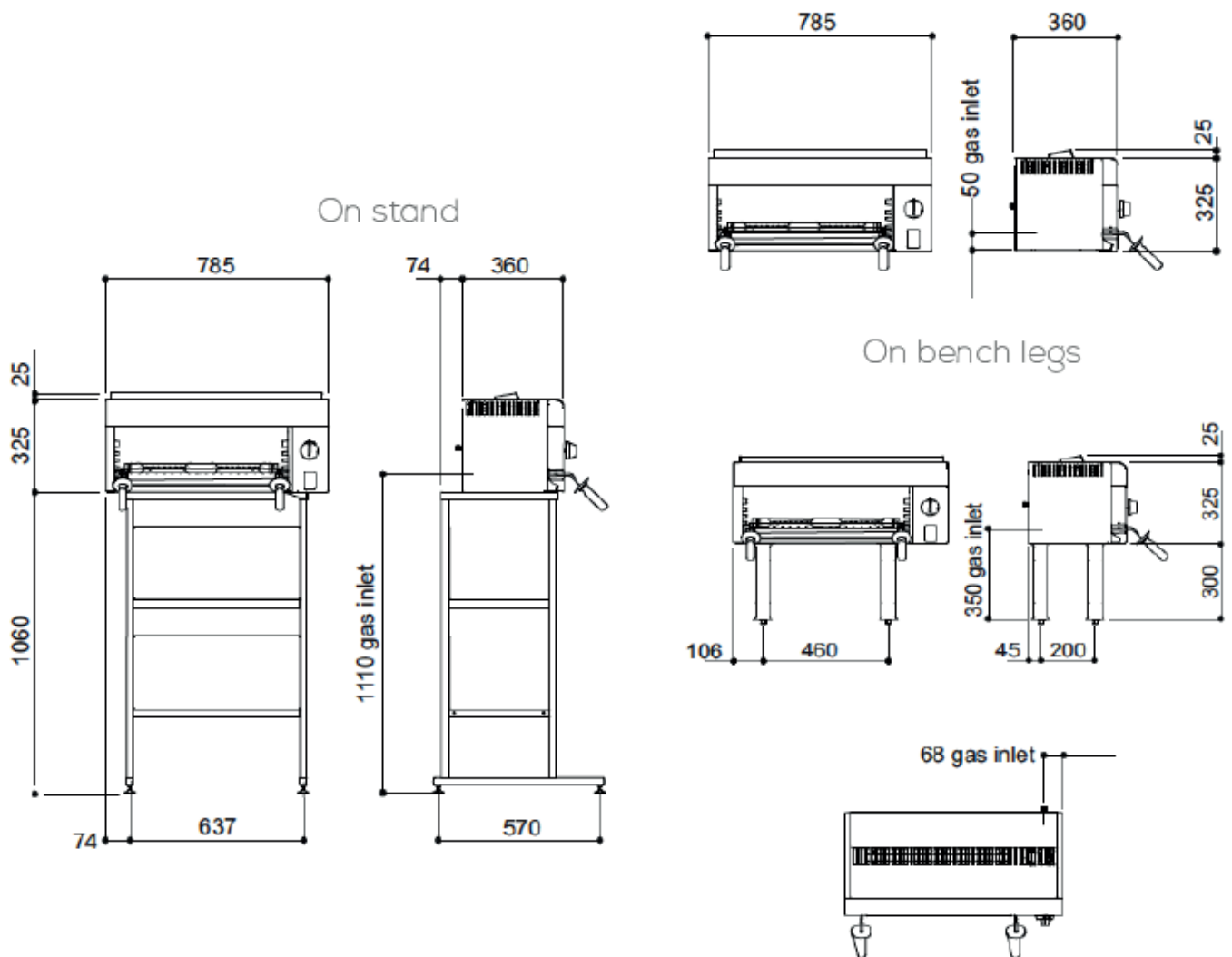

# SERVICELINE

Catering & Refrigeration Equipment Sales  Est. 1989



01438 363 040

ServiceLine 1 Icen Ct, Icknield Way, Letchworth Garden City SG6 1TN