

SERVICELINE

Catering & Refrigeration Equipment Sales  Est. 1989



**FALCON G9781-150 GAS
F900 BOILING PAN**

FALCON G9781-150 GAS F900 BOILING PAN

SPECIFICATION DETAILS	Natural Gas	Propane Gas	Butane Gas
Total rating (kW - Nett)	(9.6 pt)	21	21
Total rating (btu/hr - gross)	78,820	78,820	78,820
Inlet size	R1/2"	R1/2"	R1/2"
Flow rate	2.22m ³ /hr	1.65m ³ /hr	1.65m ³ /hr
Inlet pressure (mbar)	20	30-36	28
Operating pressure (mbar)	16-25	34-45	20-25
Burner rating (kW - Nett)	21	21	21
Burner rating (btu/hr - gross)	78,820	78,820	78,820
Water connection	3/4" BSP	3/4" BSP	3/4" BSP
Water Pressure Weight (kg)	50-300	50-300	50-300
Weight (kg)	140	140	140
Packed weight (kg)	165	165	165
Packed dimensions (mm) (wxdxh)	870x1070x1270	870x1070x1270	870x1070x1270
Packed Weight (kg)	157	157	157

KEY FEATURES

- 150 litre stainless steel pan
- Integrated water faucet
- Counter-balanced lid
- Ideal for bulk cooking
- Quick and easy to add water as required
- Leave lid as open as required during cooking

ACCESSORIES

- Front hob rail
- Rear blanking plate
- Vented front kick strip
- Side hob extension
- Side kick strips RH/LH
- Castors

Similar Models

- G9781-100
- E9781-100
- E9781-150

SHORT FORM SPECIFICATION

With a capacity of 150 litres, the G9781 boiling pan is ideal for bulk production kitchens such as hospitals, prisons and service stations. The unit features an integrated water faucet and drain for ease of cleaning, a dual pan which protects the food from fierce direct heat, and a counter-balanced lid to enable incremental opening, allowing heat to be retained when monitoring cooking progress. The pan is manufactured in square casing to enable it to be suited with other models in the F900 range via the patented Dynamic Link System (DLS)

The unit is supplied on adjustable feet, with optional castors available

INSTALLATION NOTE

Please consult local legislation with regard to installation of cooking equipment.

DIMENSIONS MEASUREMENTS IN MM

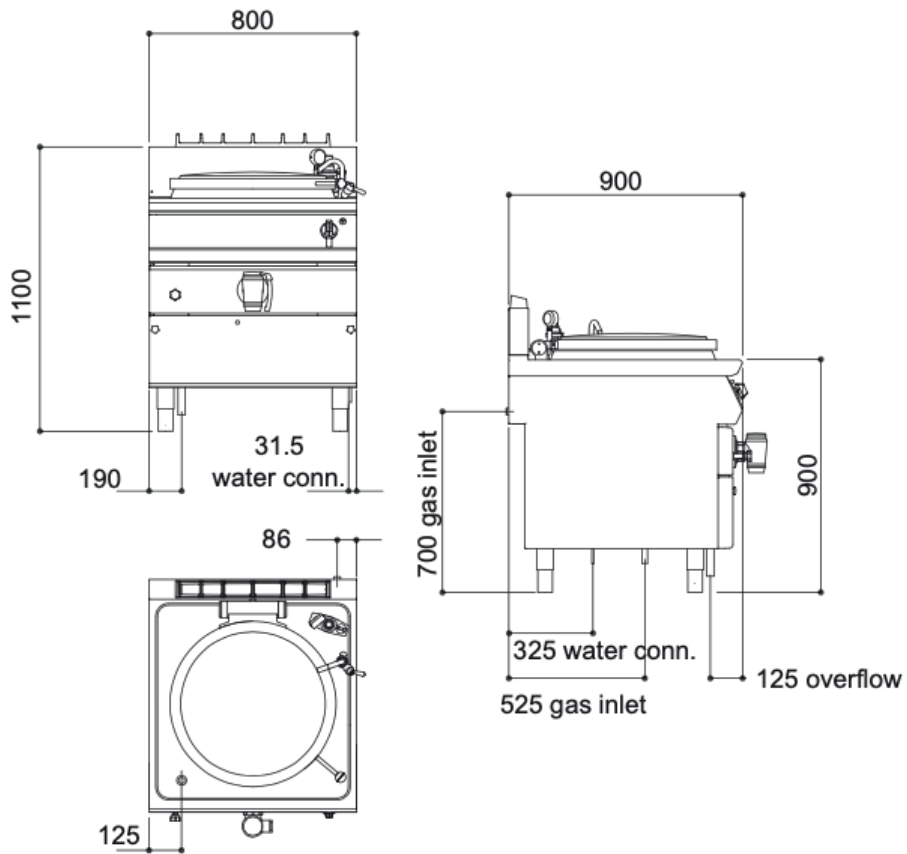

SERVICELINE

Catering & Refrigeration Equipment Sales  Est. 1989



01438 363 040

ServiceLine 1 Icen Ct, Icknield Way, Letchworth Garden City SG6 1TN